

# DECOILER

TYPE RS 05HW

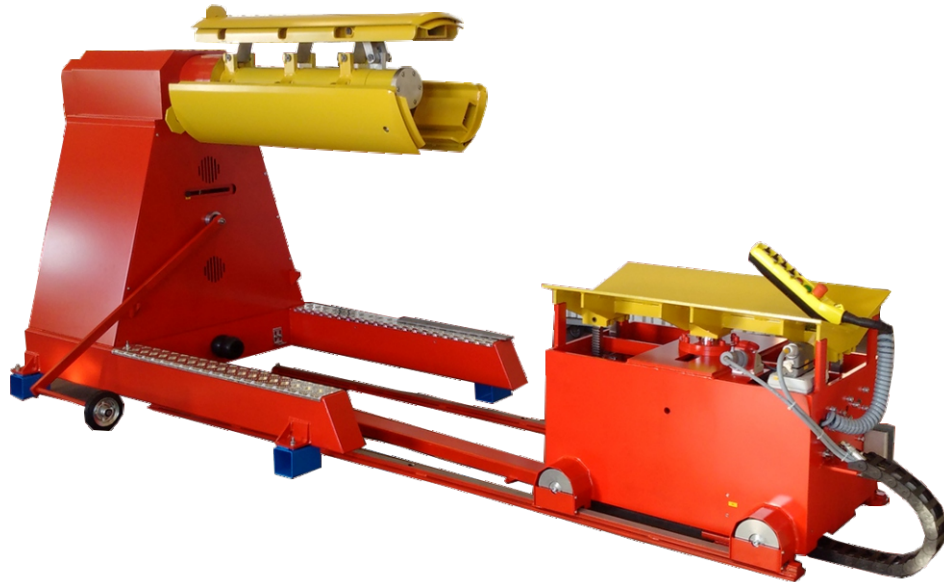

Maximal weight of the coil	5000 kg
Sheet metal thickness range	from 0,4 mm up to 1 mm
Maximal external diameter of the coil	1100 mm
Internal diameter of the coil	508 mm
Maximal width of the coil	1250 mm
Height of mandrel axis	1300 mm
Maximal velocity	30 m/min
Mandrel drive	electric
Speed regulation	automatic, loop control arm
Mandrel jaws extending method	hydraulic
Coilcar	hydraulic
Coilcar's platform stroke	370 mm
Mass of the machine	2050 kg

# RS 05HW

# DECOILER

TYPE RS 05HW

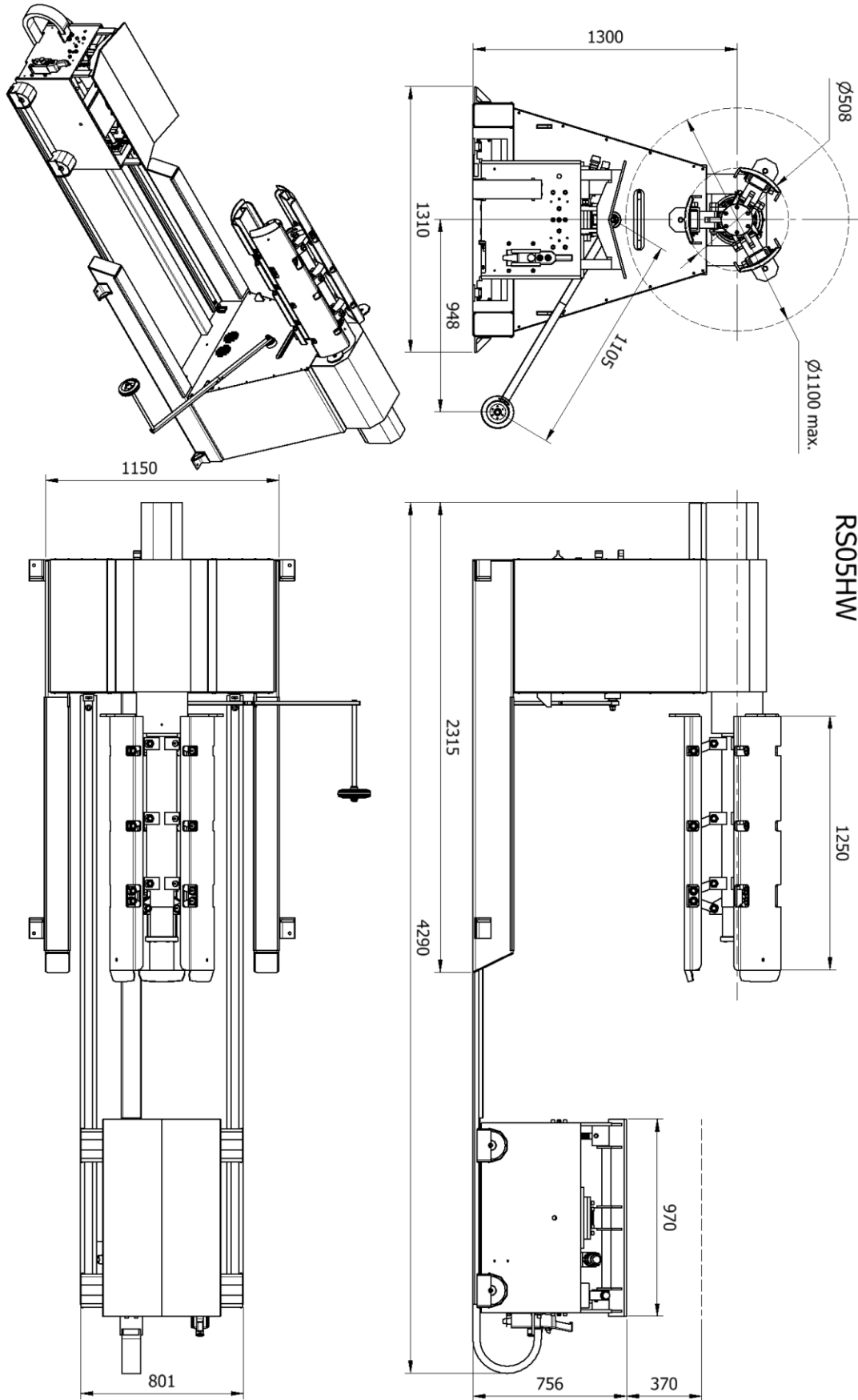

# RS 05HW