

DECOILER

TYPE RS 10HWOp



Maximal weight of the coil	10000 kg
Sheet metal thickness range	from 0,4 mm up to 1 mm
Maximal external diameter of the coil	1250 mm
Internal diameter of the coil	508 mm / 610 mm
Maximal width of the coil	1250 mm
Height of mandrel axis	1400 mm
Maximal velocity	30 m/min
Mandrel drive	electric
Speed regulation	automatic, loop control arm
Mandrel jaws extending method	hydraulic
Coilcar	hydraulic, manually rotated platform
Coilcar's platform stroke	306 mm
Mass of the machine	2880 kg

RS 10HWOp

DECOILER

TYPE RS 10HWOp

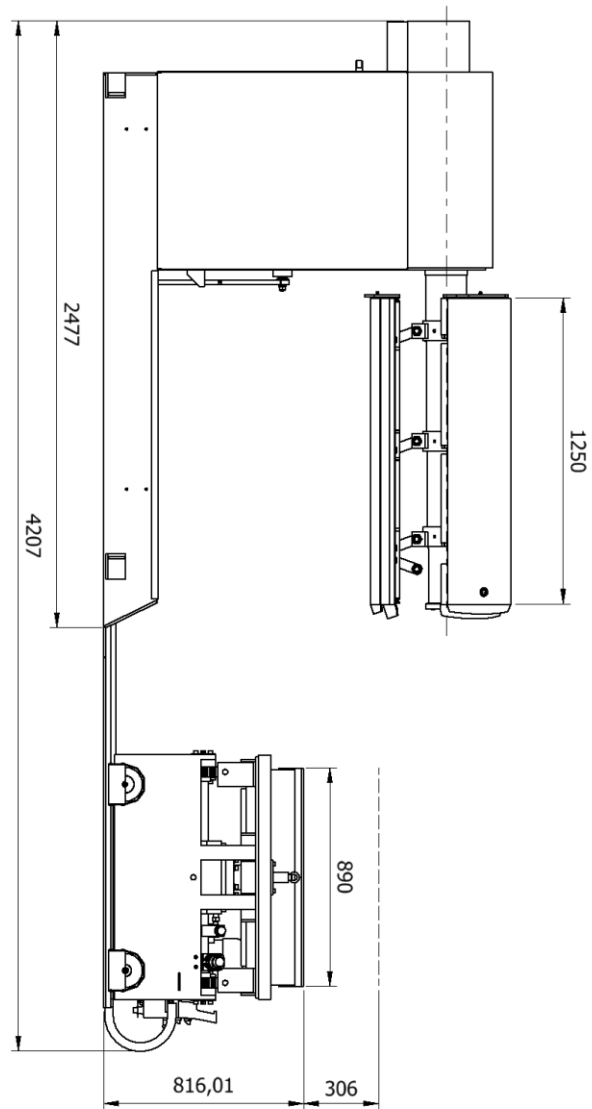
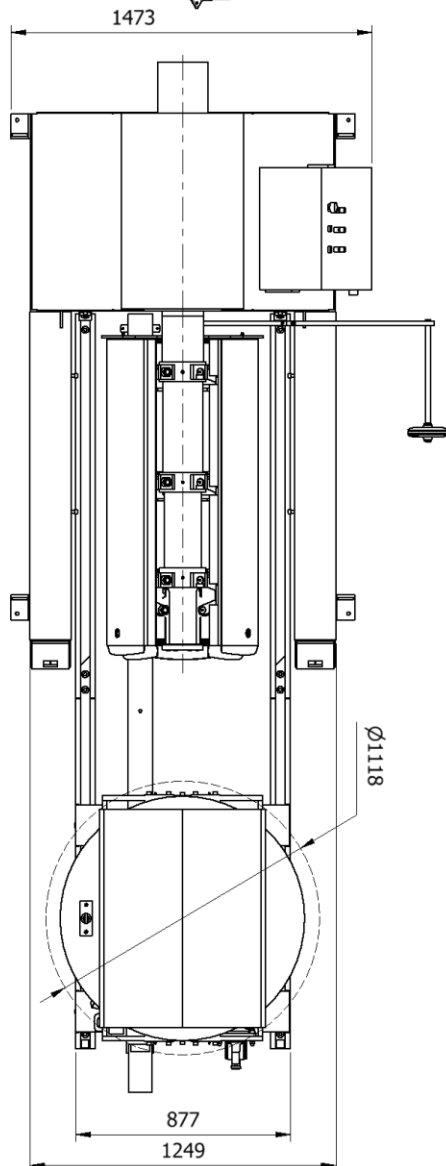
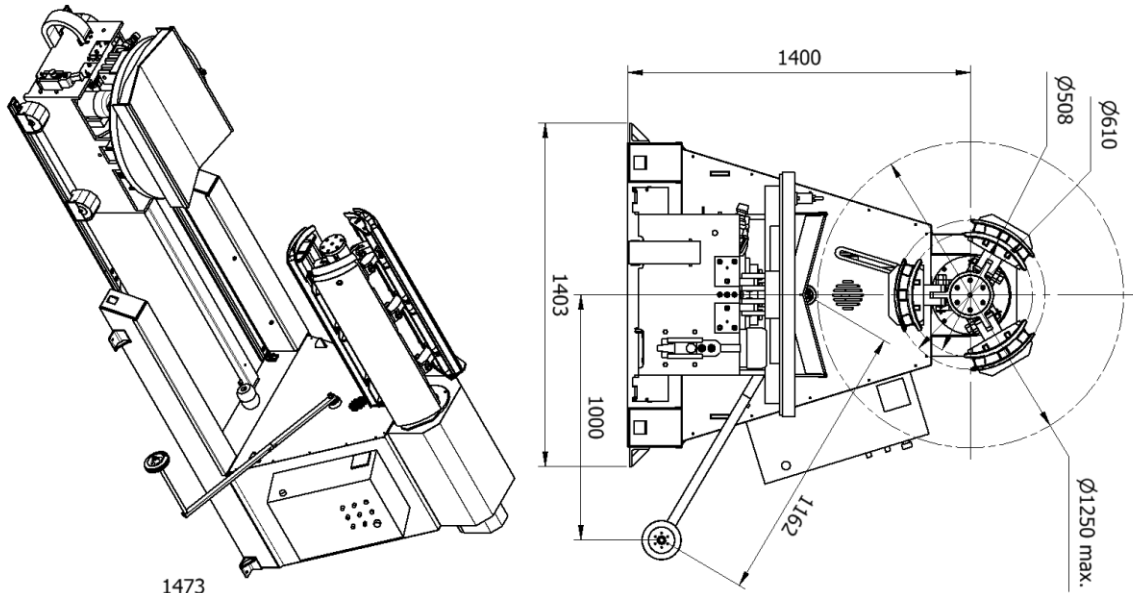

RS10HWOp

RS 10HWOp