

# DECOILER

TYPE RS 12HWP-DE



Maximal weight of the coil	12000 kg
Sheet metal thickness range	from 0,4 mm up to 2 mm
Maximal external diameter of the coil	1400 mm
Internal diameter of the coil	508 mm / 610 mm
Maximal width of the coil	1500 mm
Height of mandrel axis	1480 mm
Maximal velocity	45 m/min
Mandrel drive	electric
Speed regulation	automatic, loop control arm
Mandrel jaws extending method	hydraulic
Mandrel's support frame	manually opened
Coilcar	hydraulic
Coilcar's platform stroke	416 mm
Pressure arm	hydraulic
Snubber roller	electrically driven, rubber
Mass of the machine	4100 kg

# RS 12HWP-DE

# DECOILER

TYPE RS 12HWP-DE

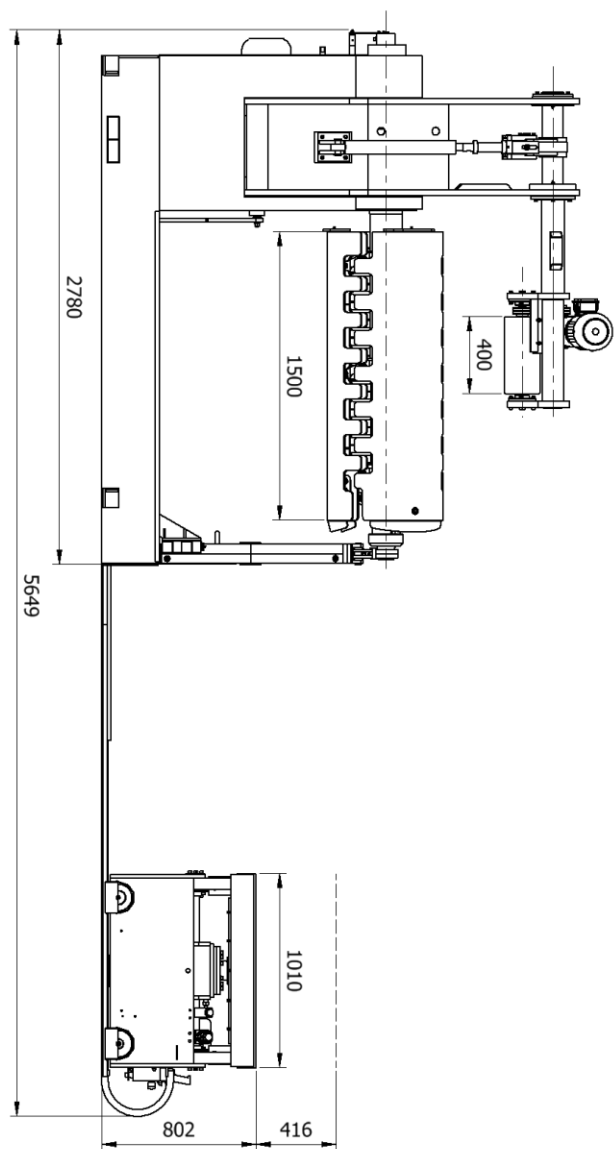
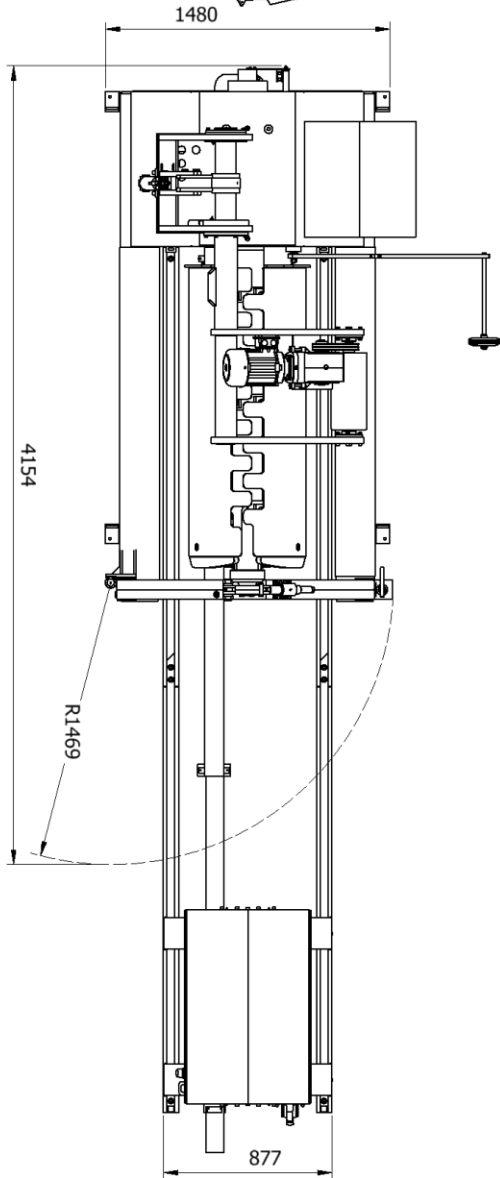
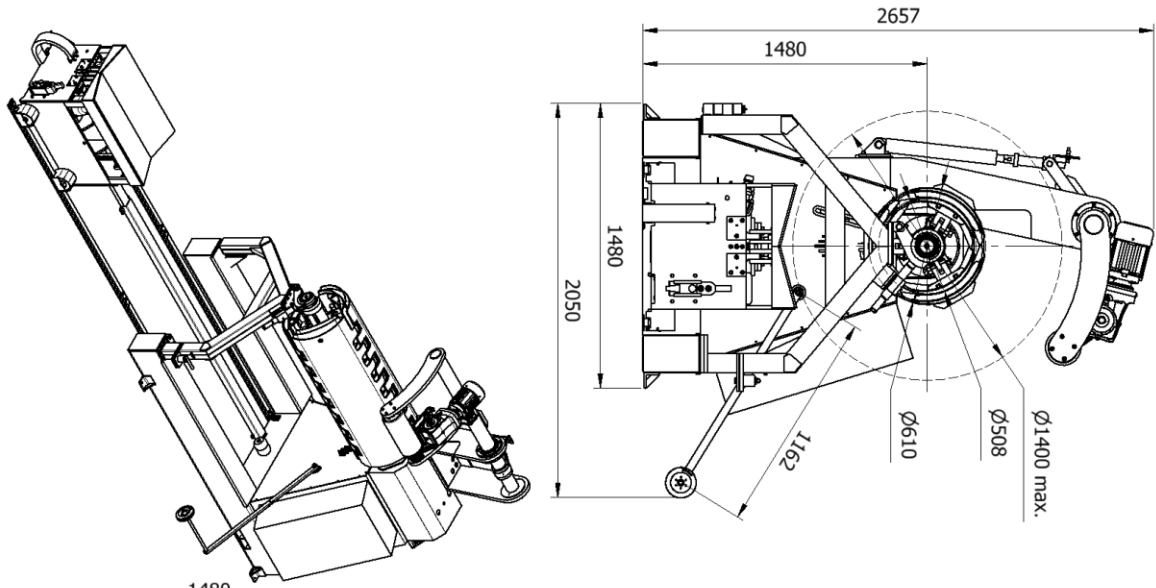

RS12HWP-DE

# RS 12HWP-DE